

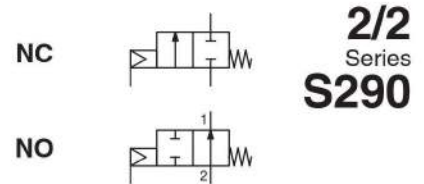

# VALVES

pressure operated  
stainless steel body  
CLAMP or butt welding connection  
DN 10 to 65



## FEATURES

- Valve with clamp type connection to ISO 2852 for quick disconnection, a system commonly used in the food processing industry or with butt welding connection to ISO 6761 for stainless steel pipe to ISO 1127
- CLAMP valve body pickled in nitric/fluoric acid bath (NET-INOX passivation treatment)
- High flow due to angled seat design
- Anti-waterhammer design (fluid entry under the disc)
- Vacuum operation up to  $10^{-2}$  mbar
- Wide range of piston-type operators (32 - 50- 63 - 90 - 125 mm dia.) rotatable through 360°, for maximum performance at different minimum pilot pressures
- High performance, maintenance-free stuffing box
- The valves satisfy Pressure Equipment Directive 97/23/EC, category 1 (DN > 25) or article 3.3 (DN ≤ 25)
- The valves in conformity with IEC 61508 Standard (2010 route 2<sub>H</sub> version) certified with integrity levels: SIL 2 for HFT = 0



## GENERAL

Differential pressure	See «SPECIFICATIONS» [1 bar = 100 kPa]
Maximum allowable pressure	16 bar
Ambient temperature range	-10°C to +60°C
Maximum viscosity	600 cSt (mm <sup>2</sup> /s)
Pilot fluid	Filtered air or water <sup>(1)</sup>
Max. pilot pressure	10 bar
Min. pilot pressure	See below and following page
Pilot fluid temperature	-10°C to +60°C
Response time	See page V402-7

fluids (*)	temperature range	disc seal (*)
DN ≤ 50 : air et gaz groupes 1 & 2 DN 65: air and gas group 2 all DN: water, oil, liquids groups 1 & 2 and steam	- 10°C to + 184°C	PTFE

## MATERIALS IN CONTACT WITH FLUID

(\*) Ensure that the compatibility of the fluids in contact with the materials is verified

<b>Valve body</b>	AISI 316L (NET-INOX treatment)
CLAMP connection	AISI 316L
Butt welding connection	AISI 316L
<b>Stuffing box housing</b>	AISI 316L
<b>Stem</b>	Stainless steel
<b>Disc</b>	Stainless steel
<b>Stuffing box packing</b>	PTFE chevrons
<b>Wiper seal</b>	FPM
<b>Disc seal</b>	PTFE
<b>Valve body seal</b>	PTFE

## OTHER MATERIALS

<b>Operator</b>	Glass fibre filled PA
<b>Optical position indicator</b>	PA 12, supplied standard on valves with 63, 90 and 125 mm operators

<sup>(1)</sup> For dia. 32, 50, 63, 90 and 125 mm operators: At service fluid temperatures inside the valve body above 100°C, it is prohibited to pilot the valve with water.

## SPECIFICATIONS

DN	O.D. of stub (clamp) (mm)	O.D. of stub (butt) (mm)	flow coefficient Kv (m <sup>3</sup> /h) (l/min)		pilot pressure (bar) min. max.		operating pressure differential (bar)			operator diameter (mm)	catalogue number		
							min.	max.			clamp connection	butt welding connection	
								air, inert gas, aggressive fluids(*)	water, oil, liquids, aggressive liquids(*)				steam (*) (≤184°C)
<b>NC - Normally closed, entry under the disc <sup>(1)</sup></b>													
10	34	17,2	2,8	47	4	10	0	16	16	10	32	S290A800	S290A802
			4,1	68	4	10	0	12	12	10	32	S290A804	S290A806
15	34	21,3	4,9	82	4	10	0	16	16	10	50	S290A408	S290A417
			2,5	10	0	16	16	10	63	S290B137	S290B205		
20	50,5	26,9	6,5	108	4	10	0	6	6	6	32	S290A808	S290A810
			9,4	157	4	10	0	10	10	10	50	S290A409	S290A418
			16	16	10	63	S290B140	S290B208					
			2,5	10	0	12	12	10	63	S290B139	S290B207		

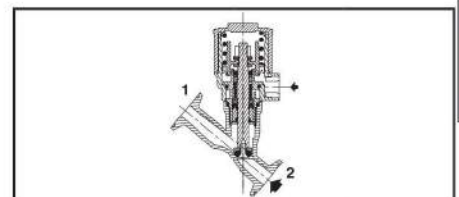

NC function, entry under the disc, 32 and 50 mm operators

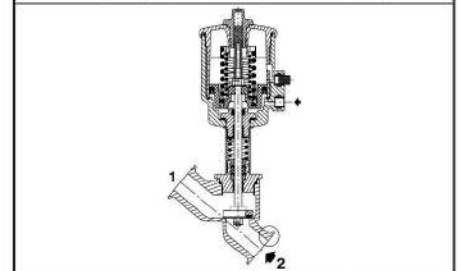

NC function, entry under the disc, 63, 90 and 125 mm operators

CLAMP connection (not supplied)

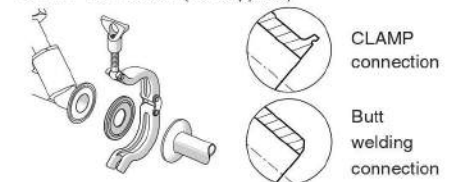

**D**

**SPECIFICATIONS**

DN	O.D. of stub (clamp) (mm)	O.D. of stub (butt) (mm)	flow coefficient Kv (m <sup>3</sup> /h)   (l/min)		pilot pressure (bar) min.   max.		operating pressure differential (bar)				operator diameter (mm)	catalogue number	
							min.	max.				clamp connection	butt welding connection
								air, inert gas, aggressive fluids(*)	water, oil, liquids, aggressive liquids(*)	steam (*) (≤184°C)			
<b>NC - Normally closed, entry under the disc <sup>(1)</sup></b>													
25	50,5	33,7	12,8	213	4	10	0	6	6	6	50	S290A410	S290A419
								10	10	10		63	S290B145
			16,5	275	4	10	0	16	16	10	90	S290B146	S290B212
								2,5	10	0	6	6	6
32	64	42,4	27	450	4	10	0	6	6	6	63	S290A151	S290A215
								12	12	10		90	-
			29	483	4	10	0	3	3	3	63	-	S290A214
								16	16	10	125	-	S290A670
40	64	48,3	45	750	4	10	0	4	4	4	63	S290A155	S290A217
								8	8	8		90	S290A156
			48	800	4	10	0	4	4	4	90	S290A154	-
								16	16	10	125	S290A521	S290A573
50	77,5	60,3	59	983	4	10	0	2,5	2,5	2,5	63	S290A687	S290A719
								6	6	6		90	S290A688
			66	1100	2,5	10	0	2,5	2,5	2,5	90	S290A685	-
								10	10	10	125	S290A689	S290A721
65	91	76,1	94	1567	4	10	0	2	2	2	90	S290A691	S290A722
								6	6	6		125	S290A690
			111	1850	4	10	0	6	6	6	125	S290A692	S290A723
								1	1	1	125	S290A692	S290A723
<b>NO - Normally open, entry under the disc</b>													
10	34	17,2	2,8	47	IX (*)	10	0	16	16	10	32	S290A812	S290A814
15	34	21,3	4,1	68	IX (*)	10	0	16	16	10	32	S290A816	S290A818
			4,9	82	I (*)	10	0	16	16	10	50	S290A411	S290A420
					II (*)	10	0	16	16	10	63	S290B161	S290B221
20	50,5	26,9	6,5	108	IX (*)	10	0	16	16	10	32	S290A820	S290A822
			9,4	157	I (*)	10	0	16	16	10	50	S290A412	S290A421
					II (*)	10	0	16	16	10	63	S290B162	S290B222
25	50,5	33,7	12,8	213	I (*)	10	0	16	16	10	50	S290A413	S290A422
			16,5	275	II (*)	10	0	16	16	10	63	S290B163	S290B223
32	64	42,4	27	450	II (*)	10	0	16	16	10	63	S290A164	S290A224
40	64	48,3	45	750	II (*)	10	0	11	11	10	63	S290A165	S290A225
50	77,5	60,3	59	983	II (*)	10	0	7	7	7	63	S290A693	S290A724
					III (*)	10	0	13	13	10	90	S290A694	S290A725
			94	1567	III (*)	10	0	7	7	7	90	S290A695	S290A726
65	91	76,1	111	1850	IV (*)	10	0	16	16	10	125	S290A696	S290A727
<b>NC - Normally closed, entry above the disc (version recommended for rapid-cycling steam applications)</b>													
10	34	17,2	2,8	47	X (*)	10	0	10	-	10	32	S290A824	S290A826
15	34	21,3	4,1	68	X (*)	10	0	10	-	10	32	S290A828	S290A830
			4,9	82	V (*)	10	0	10	-	10	50	S290A414	S290A423
					VI (*)	10	0	10	-	10	63	S290B167	S290B227
20	50,5	26,9	6,5	108	X (*)	10	0	10	-	10	32	S290A832	S290A834
			9,4	157	V (*)	10	0	10	-	10	50	S290A415	S290A424
					VI (*)	10	0	10	-	10	63	S290B168	S290B228
25	50,5	33,7	12,8	213	V (*)	10	0	10	-	10	50	S290A416	S290A425
			16,5	275	VI (*)	10	0	10	-	10	63	S290B169	S290B229
32	64	42,4	27	450	VI (*)	10	0	10	-	10	63	S290A170	S290A230
40	64	48,3	45	750	VI (*)	10	0	10	-	10	63	S290A171	S290A231
50	77,5	60,3	59	983	VII (*)	10	0	10	-	10	90	-	S290A259
					VI (*)	10	0	9	-	9	63	S290A697	S290A728
			94	1567	VII (*)	10	0	10	-	10	90	S290A698	S290A729
65	91	76,1	111	1850	VIII (*)	10	0	10	-	10	125	S290A699	S290A730
												S290A700	S290A731

(\*) Minimum pilot pressure varies with differential pressure, see page V402-7.

<sup>(1)</sup> Calculation of the minimum pilot pressure at a ΔP of max. 10 bar with allowable backpressure (backpressure not recommended with liquids as waterhammer may occur).

- 32 and 50 mm operators, 4 bar minimum pilot pressure version: add 2 bar to the minimum pilot pressure of chart V or X, page V402-7..

- 63, 90 and 125 mm operators, 4 bar minimum pilot pressure version: add 1,5 bar to the minimum pilot pressure of chart VI, VII or VIII, page V402-7.

### OPTIONS AND ACCESSORIES (see page V435/V436)

- Signaling box or compact signaling unit
- Stroke limiter for opening
- Manual safety device
- Optical position indicator on 32-50 mm operators, NC function
- Adapter plate for NAMUR pad mounting pilot (63-90-125 mm operators only)
- Oxygen service (except DN 65), pressure limited to 15 bar, temperature limited to + 60°C
- Vacuum applications up to 1,33 10<sup>-3</sup> mbar
- NET-INOX passivation treatment on valve body with butt welding connection
- ATEX 94/9/EC versions for potentially explosive atmospheres

### INSTALLATION

- The valves can be mounted in any position without affecting operation
- On clamp connection version: The connection stubs comply with ISO 2852.  
The strength of the quick-disconnect connection clamp must be compatible with the maximum pressure applied to the valve
- On butt welding version: Compatible with ASTM 1, 2 and 3 oils  
Butt welding connections comply with ISO 6761 and are compatible with pipe to ISO 1127
- Check temperature range of valve body and solenoid pilot valves for suitability. For probability of failure, contact us
- Installation/maintenance instructions are included with each valve

### SPARE PARTS KITS

DN	spare parts kit no.	
	Ø 32 mm	Ø 50-63-90-125 mm
10	<b>C140100</b>	-
15	<b>C140101</b>	<b>C131204</b> <sup>(1)</sup>
20	<b>C140102</b>	<b>C131205</b> <sup>(1)</sup>
25	-	<b>C131206</b> <sup>(1)</sup>
32	-	<b>C131207</b> <sup>(1)</sup>
40	-	<b>C131208</b> <sup>(1)</sup>
50	-	<b>C131209</b> <sup>(1)</sup>
65	-	<b>C131622</b> <sup>(1)</sup>

<sup>(1)</sup> Standard suffix VM also applies to kits (see V435).  
- Not available

### ORDERING EXAMPLES:

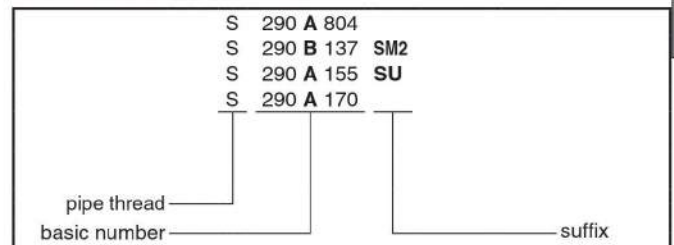

### ORDERING EXAMPLES KITS:

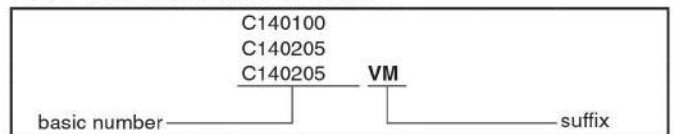

### DIMENSIONS (mm), WEIGHT



#### TYPE 01-02-03-04-05

clamp connection  
32, 50, 63, 90 and 125 mm operators  
Fluid entry: under the disc at 2  
above the disc at 1

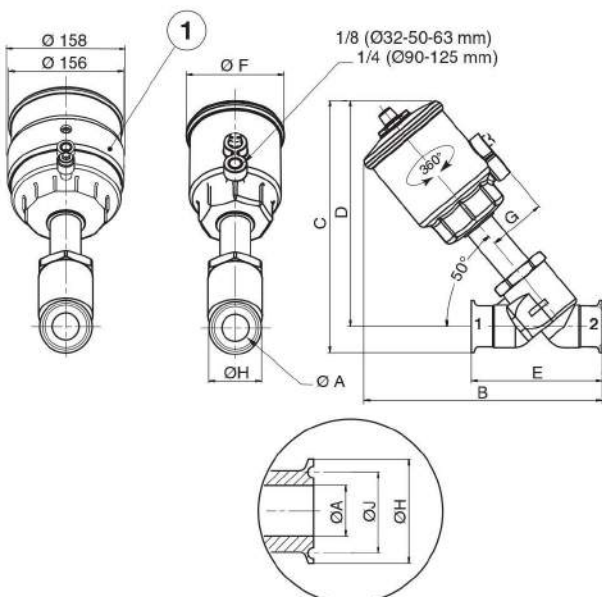

type	operator diameter	DN	ØA	B	C	D	E	ØF	G	ØH	ØJ	weight <sup>(1)</sup>
01	32	10	10	102,5	104,7	87,7	80	43,5	27	34	27,5	0,4
		15	16	110,7	105,8	88,8	101,6	43,5	27	34	27,5	0,43
		20	20	111,6	113,6	88,4	114	43,5	27	50,5	43,5	0,59
02	50	15	15,5	153	158,5	141	102	69	43	34	27,5	0,9
		20	21,5	158	168	143	114	69	43	50,5	43,5	1
		25	26	167	170,5	145	129	69	43	50,5	43,5	1,4
03	63	15	15,5	182	186	169	102	85	50,5	34	27,5	1,2
		20	21,5	184	195	170	114	85	50,5	50,5	43,5	1,3
		25	26	191	197	172	129	85	50,5	50,5	43,5	1,7
		32	35	226	236	204	140	85	50,5	64	56,5	2,1
		40	41	235	247	215	159	85	50,5	64	56,5	2,8
04	90	50	50	257	263	224	180	85	50,5	77,5	70,5	3,7
		25	26	209	214	189	129	118	67	50,5	43,5	2,2
		32	35	245	253	221	140	118	67	64	56,5	2,7
		40	41	254	264	232	159	118	67	64	56,5	3,4
		50	50	275	280	241	180	118	67	77,5	70,5	4,2
05	125	65	65	302	302,5	257	205	118	67	91	83,5	6,2
		32	35	291	307	273	140	156	86	64	56,5	5,2
		40	41	301	316	284	159	156	86	64	56,5	5,9
		50	50	322,5	332	293	180	156	86	77,5	70,5	6,7
		65	65	349,5	353,5	308	205	156	86	91	83,5	8,8

① Operator dia. 125 mm, NO function

<sup>(1)</sup> Weight of valve without pilot. Add 0,2 for dia. 125 mm operator NO.  
Solenoid pilot valves: see V439 (63 mm operator) / V444 (90 and 125 mm operators).

### DIMENSIONS (mm), WEIGHT



#### TYPE 01-02-03-04-05

butt welding connection  
32, 50, 63, 90 and 125 mm operators  
Fluid entry: under the disc at 2  
above the disc at 1

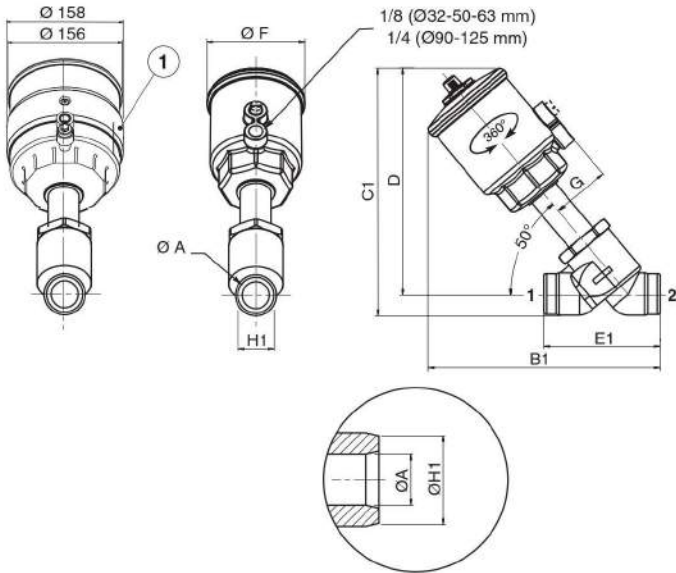

type	operator diameter	DN	ØA	B1	C1	D	E1	ØF	G	ØH1	weight <sup>(1)</sup>
01	32	10	10	102,5	96,9	87,7	80	43,5	27	17,2	0,37
		15	16	101,9	100,5	88,8	84	43,5	27	21,3	0,4
		20	20	103,6	102,4	88,4	98	43,5	27	26,9	0,45
02	50	15	15,5	144	152	141	84	69	43	21,3	0,9
		20	21,5	150	157	143	98	69	43	26,9	1
		25	26	159	162	145	113	69	43	33,7	1,3
03	63	15	15,5	172	181	169	84	85	50,5	21,3	1,2
		20	21,5	175	184	170	98	85	50,5	26,9	1,3
		25	26	183	190	172	113	85	50,5	33,7	1,6
		32	35	218	226	204	124	85	50,5	42,4	2
		40	41	227	240	215	143	85	50,5	48,3	2,7
		50	50	249	254	224	164	85	50,5	60,3	3,6
04	90	25	26	201	207	189	113	118	67	33,7	2,1
		32	35	237	243	221	124	118	67	42,4	2,6
		40	41	246	257	232	143	118	67	48,3	3,3
		50	50	267	271	241	164	118	67	60,3	4,1
		65	65	294	295	257	189	118	67	76,1	6,1
05	125	32	35	283	295	273	124	156	86	42,4	5,1
		40	41	294	308	284	143	156	86	48,3	5,8
		50	50	314,5	323	293	164	156	86	60,3	6,7
		65	65	341,5	346	308	189	156	86	76,1	8,7

① Operator dia. 125 mm, NO function

<sup>(1)</sup> Weight of valve without pilot. Add 0,2 for dia. 125 mm operator NO.  
Solenoid pilot valves: see V439 (63 mm operator) / V444 (90 and 125 mm operators).

32 mm operator	50 mm operator	63, 90 and 125 mm operators
NO function		
NC function, entry above the disc		